

圧入後寸法

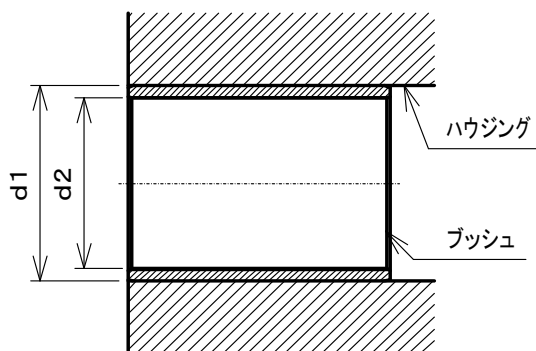

※圧入後ブッシュ内径公差の変化(参考値)

d	ハウジング径(H7) d1	圧入後内径 d2
6	+0.012 0	+0.062 0
8~10	+0.015 0	+0.065 0
12~16	+0.018 0	+0.068 0
20	+0.021 0	+0.071 0
25~30	+0.021 0	+0.081 0

型式	d	D	公差	T	公差	L
DZK6-8-5	6	8	+0.055 +0.025	1	+0.005 -0.02	5
DZK6-8-6	6	8				6
DZK6-8-8	6	8				8
DZK8-10-6	8	10	+0.055 +0.025	1	+0.005 -0.02	6
DZK8-10-8	8	10				8
DZK8-10-10	8	10				10
DZK8-10-12	8	10				12
DZK10-12-6	10	12	+0.065 +0.030	1	+0.005 -0.02	6
DZK10-12-8	10	12				8
DZK10-12-10	10	12				10
DZK10-12-12	10	12				12
DZK10-12-15	10	12				15
DZK12-14-6	12	14	+0.065 +0.030	1	+0.005 -0.02	6
DZK12-14-8	12	14				8
DZK12-14-10	12	14				10
DZK12-14-12	12	14				12
DZK12-14-15	12	14				15
DZK16-18-10	16	18	+0.065 +0.030	1	+0.005 -0.02	10
DZK16-18-12	16	18				12
DZK16-18-15	16	18				15
DZK16-18-20	16	18				20
DZK16-18-25	16	18				25

型式	d	D	公差	T	公差	L
DZK20-23-10	20	23	+0.075 +0.035	1.5	+0.005 -0.025	10
DZK20-23-12	20	23				12
DZK20-23-15	20	23				15
DZK20-23-20	20	23				20
DZK20-23-25	20	23				25
DZK20-23-30	20	23				30
DZK25-28-10	25	28	+0.075 +0.035	1.5	+0.005 -0.025	10
DZK25-28-12	25	28				12
DZK25-28-15	25	28				15
DZK25-28-20	25	28				20
DZK25-28-25	25	28				25
DZK25-28-30	25	28				30
DZK30-34-15	30	34	+0.085 +0.045	2	+0.005 -0.03	15
DZK30-34-20	30	34				20
DZK30-34-25	30	34				25
DZK30-34-30	30	34				30

部位	材質、処理
ケース	SPCC+スズメッキ
焼結層	青銅
樹脂層	四フッ化エチレン樹脂